

INFORMATION, Vol.13 Number 3(A), May 2010

# A QPSK-CDMA Based Acoustic Communication System for Multiple Underwater Vehicles

Zixin Zhao and Shuxiang Guo

International Information Institute

## A QPSK-CDMA Based Acoustic Communication System for Multiple Underwater Vehicles

Zixin Zhao\*, Shuxiang Guo\*\*

*\*Graduate School of Engineering, Kagawa University,  
Hayashi-cho, Takamatsu, 761-0396, Japan  
s08d506@stmail.eng.kagawa-u.ac.jp*

*\*\*Department of Intelligent Mechanical Systems Engineering, Kagawa University  
Hayashi-cho, Takamatsu, 761-0396, Japan*

### Abstract

This paper proposes an underwater acoustic communication system based on QPSK-CDMA (Quadrature Phase Shift Keying-Code Division Multiple Access) for multiple underwater vehicles. Through this system, multiple underwater vehicles can communicate with the console on the water surface simultaneously successfully. The communication system is composed of channel encoding and decoding, spread spectrum modulation and demodulation, RF (Radio Frequency) modulation, Rake Receiver and synchronization. As an important factor that affects the quality of acoustic communication, underwater acoustic channel is also taken into account. The simulation results indicate that it is feasible to use this system to accomplish underwater communication reliably due to the small BER (Bit Error Ratio).

**Key Words:** Underwater acoustic communication, QPSK, CDMA, Synchronization, Multiple underwater vehicles

### 1. Introduction

As more and more attention is paid to the ocean, the requirement of exploration and exploitation to the ocean is growing increasingly. In order to realize some tasks such as collection of the information, monitoring of the environment, exploration of energy sources, forecast of natural disaster, assistant navigation in the ocean, underwater communication technology is necessary, which has become a very important scientific research field in recent years.

Because acoustic wave is adopted to actualize communication underwater instead of electromagnetic wave, it is called underwater acoustic communication. However, the complex environment in the ocean makes it rather difficult to communicate normally, such as the problems of high noise, multipath effect and large delay. So far, many researches have been made to ensure the reliability of communication underwater, including the simulation and measure of the channel [1][2]; research on the use and algorithm of signal processor in the receiver [3][4]; diversity reception technique [5][6] and coding technique (compression coding and error correction coding) [7][8]. As the tasks that we require underwater vehicles to undertake grow more and more complicated, precise and various, only an underwater vehicle can hardly satisfy all the requirements. Multiple underwater vehicles system is one of the most important developmental directions. Our goal is to set up a communication network to ensure the vehicles to work under control normally. At present, multiple access based on spread spectrum technique is necessary to realize communication between multiusers. Ref [9] proposed a low SNR (Signal to Noise Ratio) underwater acoustic communication system using direct sequence spread spectrum signals, but how to put them to use in the situation of

multiusers wasn't discussed. Ref. [10] proposed a novel multichannel detection technique based on adaptive multichannel receiver to realize multiuser underwater acoustic communication, but as a whole system, the communication quality was unknown (such as BER). Ref [11] proposed the idea of controlling underwater vehicles by way of underwater acoustic networks and introduced the hardware, but the communication approach wasn't explained in detail. In order to solve these problems, this paper proposes an underwater acoustic communication system based on QPSK-CDMA for multiple underwater vehicles to communicate simultaneously to the console on the water surface. Spread spectrum, channel coding and Rake Receiver are adopted to improve the communication reliability. Besides, synchronization parts and underwater acoustic channel are also taken into account. Especially, the concept of multiuser will be helpful in the construction of underwater acoustic network.

This paper is organized as follows: Part II analyzes underwater acoustic channel, which is a very important influencing factor in communication system. Part III expounds the communication approaches, including the working principle, the components and the structure of the system. The simulation results are shown in Part IV. Finally, the conclusions are made and the future research in this field is presented.

## 2. Underwater Acoustic Channel

Channel is a very important component in communication system. Its characteristics have great influence on the effect of communication. In this part, underwater acoustic channel will be analyzed.

### 2.1 Characteristics of underwater acoustic channel

Underwater acoustic channel is the most complex communication channel that we have known about. It brings many difficulties to underwater communication. The characteristics of underwater acoustic channel are limitation of the frequency bandwidth, varying multipath, fast fading and high noise.

The absorption and the diffusion of acoustic energy relate to transmission distance and frequency. That is to say transmission loss increases as transmission distance and frequency increase. This characteristic results in great attenuation of high frequency signal in long distance transmission. Ref. [8] points out that the bandwidth can be larger than 100kHz in near distance (<1km); in middle distance (1-20km), the bandwidth is limited in the magnitude of ten kilohertz; the bandwidth is only about several kilohertz in long distance (20-2000km).

There are many noise sources in the ocean. Some typical noise sources are listed as the frequency rises [9]. The effect of hydrostatic pressure caused by tide and wave; disturbance of earthquake; onflow; sailing ship; surface wave; thermal noise. For the frequency in the magnitude of ten kilohertz, a main noise source is surface wave. The high noise will cause the original signal difficult to recover.

Because of the reflection of the surface and the floor of ocean as well as the existent of reflectors and scatterers caused by the organisms, acoustic wave will reach the receiving part along several different paths after it is sent. This phenomenon is called multipath transmission. It's a most important factor that affects the performance of underwater acoustic communication. Multipath transmission results in signal distortion (fast fading) and selective fading. The amplitude and the phase of the signal will change along with time and frequency which brings on errors in the receiving part. In order to solve the problem, equalization technique, diversity technique, spread spectrum technique and array

technique can be adopted.

## 2.2 The model of underwater acoustic channel

Because underwater acoustic channel is very complex, it can't be represented by a precise simulation model. Generally speaking, underwater acoustic channel is a kind of slow time-varying coherent multipath channel. In the length of coherent time, it can be simplified as a coherent multipath channel, which only has multipath effect. In this paper, a typical model of acoustic ray is adopted to implement the simulation. The model is expressed as Figure 1 [10].

When the input signal is  $s(t)$ , the output signal is

$$r(t) = \sum_{k=1}^L a_k(t)s(t - \tau_k(t)) + n(t) \quad (1)$$

where  $L$  is the number of multipath;  $a_k(t)$  is the time-varying attenuation factor in the  $k_{th}$  transmission path;  $\tau_k(t)$  is the delay;  $n(t)$  is additive white noise.

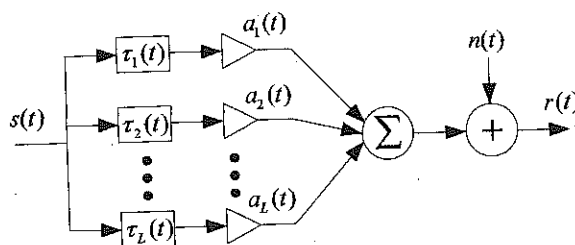

Figure. 1. The Model of Time-varying Multipath Channel with Additive White Noise

## 3. Communication Approaches

Because the underwater environment is rather complex, it is very important to decide the structure and the method of communication to ensure the reliability. In this part, the working principle and the structure of the system will be expounded in detail.

### 3.1 Spread spectrum communication

Spread spectrum communication is a communication method that spreads the signal which is to be sent to a wide frequency band. The frequency band is much wider than the bandwidth of the original signal. In the receiving part, after correlative reception, the signal is recovered to the bandwidth of the original signal.

The theoretical basis of spread spectrum communication is Shannon Formula

$$C = B \log_2(1 + S/N) \quad (2)$$

where  $C$  : channel capacity, bit/s;

$B$  : bandwidth of the signal, Hz;

$S$  : average power of the signal, W;

$N$  : power of the noise, W.

From Shannon Formula, it is obtained that if channel capacity is a constant, we can reduce the requirement of SNR by way of increasing the bandwidth; on the other hand, we can also enhance the power of the signal to decrease the bandwidth. Therefore, when SNR is very low (in the ocean for

example), it is feasible to extend the bandwidth of the signal by many times to ensure the reliability of communication. And the resistance capability against the noise of the system is greatly improved. Meanwhile, the spread spectrum technique has the characteristic of resistance to multipath, which is also very helpful in underwater acoustic communication.

### 3.2 DS-CDMA system

CDMA system allows multiple users to communicate simultaneously over the entire frequency band. Signals from different users are distinguished by means of PN codes that are used for spreading the messages sent from the users. The PN codes of different users are mutually orthogonal. In the receiving part, only when the PN code which is absolutely the same as the PN code of the transmitting part is adopted, the signal could be recovered correctly. Because signals from the other users are not correlative with the PN code, they are regarded as noise and have little effect on the communication system.

There are three basic spreading techniques: DS (Direct Sequence), FH (Frequency Hopping) and TH (Time Hopping) spread spectrum.

In the DS-CDMA system, original signal is linearly modulated using wide-band PN code. It is convenient for spreading the frequency spectrum and is widely used in the communication field at present. If QPSK is adopted as the modulation method, it is called QPSK-CDMA which is shown in Figure 2.

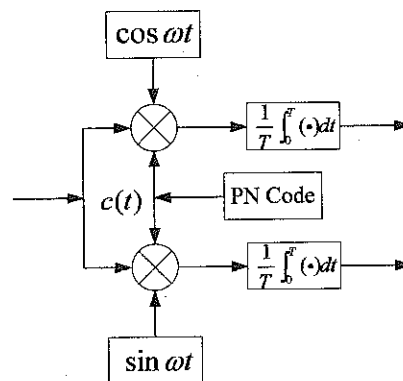

Figure 2. The Configuration of QPSK-CDMA

### 3.3 Channel coding and decoding

In underwater acoustic communication, due to the effect of channel characteristics and noise, errors are brought on in the received signal inevitably. In order to achieve the target of low BER, it is necessary to adopt channel coding. Generally speaking, there are mainly two kinds of errors in the communication channel: random error and burst error. Accordingly, error correction coding is to solve random error and interleaving is to solve burst error.

Random errors happen in random channel such as AWGN (Additive White Gaussian Noise) channel. The errors occur randomly and they are mutually statistical independent.

In this paper, error correction code is RS (Reed-Solomon) code. RS code is the origin BCH code of  $n = 2^m - 1$  in finite field  $GF(2^m)$ . RS code can be expressed by  $(n, k)$ ,  $0 < k < n < 2^m + 2$ , where  $m$  is the number of bit in each code,  $n$  is the length of the code,  $k$  is the number of original code

element in each group.  $2t = n - k$  is the monitor code and  $t$  is the number of errors that can be corrected by RS code. The generator polynomial of RS code has the form as follows

$$g(X) = g_0 + g_1X + g_2X^2 + \dots + g_{2t-1}X^{2t-1} + X^{2t} \quad (3)$$

Burst errors happen in burst channel such as impulse interference and fading in the channel. A mass of errors occur concentratedly in some very short time. But in other time, there is no error. A kind of method to solve this problem in practice is interleaving, which can be referred to Ref. [11].

In the underwater acoustic channel, random error and burst error always exist, so error correction coding and interleaving are adopted together usually. In this paper, only random errors are taken into account for convenient, and the interleaving part is ignored.

### 3.4 Rake receiver

Diversity is a technique which is to reduce the influence of signal fading caused by multipath effect. The basic idea is to divide the received multipath signals into uncorrelated signals, and then to combine the signal energy according to some rule to obtain the energy of the useful signals as much as possible. In this way, the harmful multipath signals are turned into useful signals. The method can maximize the energy of the received useful signals which can improve SNR.

In the spread spectrum communication system, Rake Receiver uses  $L$  correlators to capture  $L$  stronger multipath components then combines the outputs through weight. The weight is decided by the output power of each path. If the output power is small, the weight is small. The working principle of Rake Receiver is shown in Figure 3.

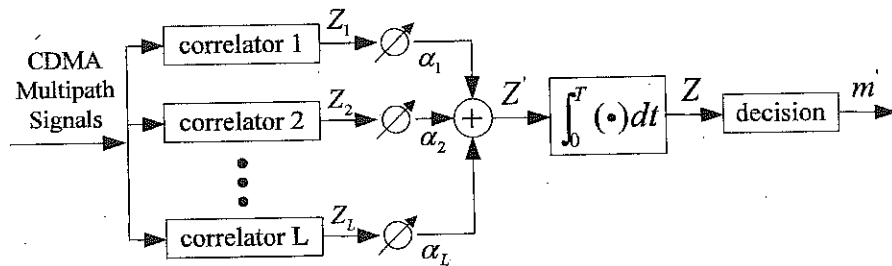

Figure 3. The Working Principle of Rake Receiver

In the figure, the output  $z'(t)$  is

$$z'(t) = \sum_{i=1}^L \alpha_i(t) z_i(t) \quad (4)$$

where the weighted coefficient  $\alpha_i(t)$  is expressed as

$$\alpha_i(t) = z_i^2(t) / \sum_{n=1}^L z_n^2(t), \quad i = 1, 2, \dots, L \quad (5)$$

### 3.5 Synchronization

There are two steps in the synchronization process of direct sequence spread spectrum: (1) capturing/coarse synchronization; (2) tracking /precise synchronization.

In this paper, sliding correlation method is adopted to capture the phase of the PN code. For the sliding correlation method, the local PN code generator works at a different code rate with the

transmitting part. If the code rate of the receiver is larger than that of the transmitter, the receiver will slide forward; otherwise the receiver will slide backward. When the two sequences are in superposition, the capturing is finished. The principle of sliding correlation is as follows.

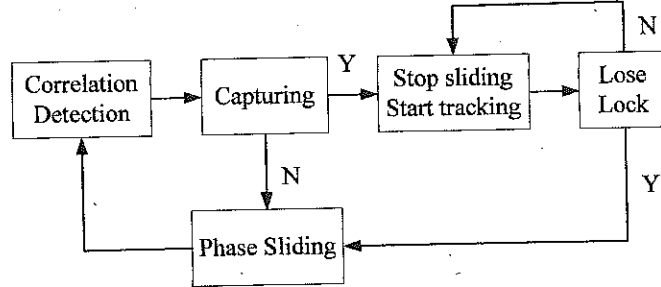

Figure. 4. The Principle of Sliding Correlation

Delay-Locked Loop can be used to realize tracking which is shown in Figure 5. After the coarse synchronization, the local PN code generator generates two sequences  $g(t+T_c/2+\tau)$  and  $g(t-T_c/2+\tau)$ , where  $g(t)$  is the input signal,  $T_c$  is the interval of code,  $\tau$  is the time interval in the phase between the local PN sequence and the received PN sequence,  $\tau < T_c/2$ . The outputs of two correlators are  $R_1(\tau)$  and  $R_2(\tau)$ , the differential output is  $e(\tau) = R_1(\tau) - R_2(\tau)$ , and the clock of the PN generator is controlled by VCO through  $e(\tau)$  to trace the PN code of the input signal.

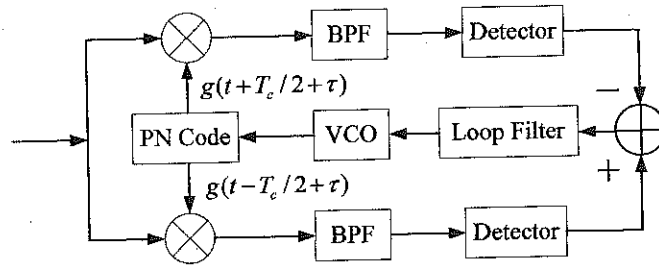

Figure. 5. Delay-Locked Loop

### 3.6 Structure and model of the communication system

The framework of the communication system is shown in Figure 6. It is composed of several underwater vehicles and a console on the surface of water. All the underwater vehicles can communicate with the console simultaneously.

Figure 7 is the principle model of the communication system. In the transmitting part, the original data (digital binary sequence) is channel encoded firstly. Then it is modulated by a series of PN (Pseudo Noise) code. The spread spectrum sequence modulates the carrier to form the RF signal and finally it is emitted to the channel through the transmitter. The receiving part is composed of three parts: (1) synchronization; (2) Rake receiver, de-spread spectrum and demodulation; (3) channel decode. The modulation method adopted in this paper is QPSK.

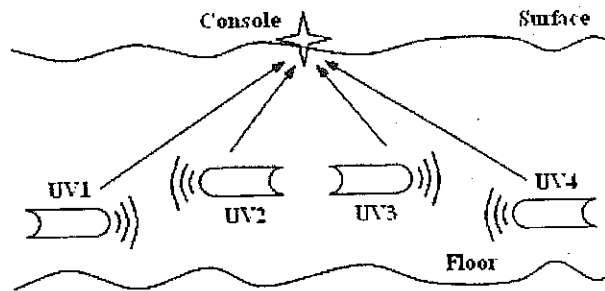

Figure 6. The Framework of the Communication System

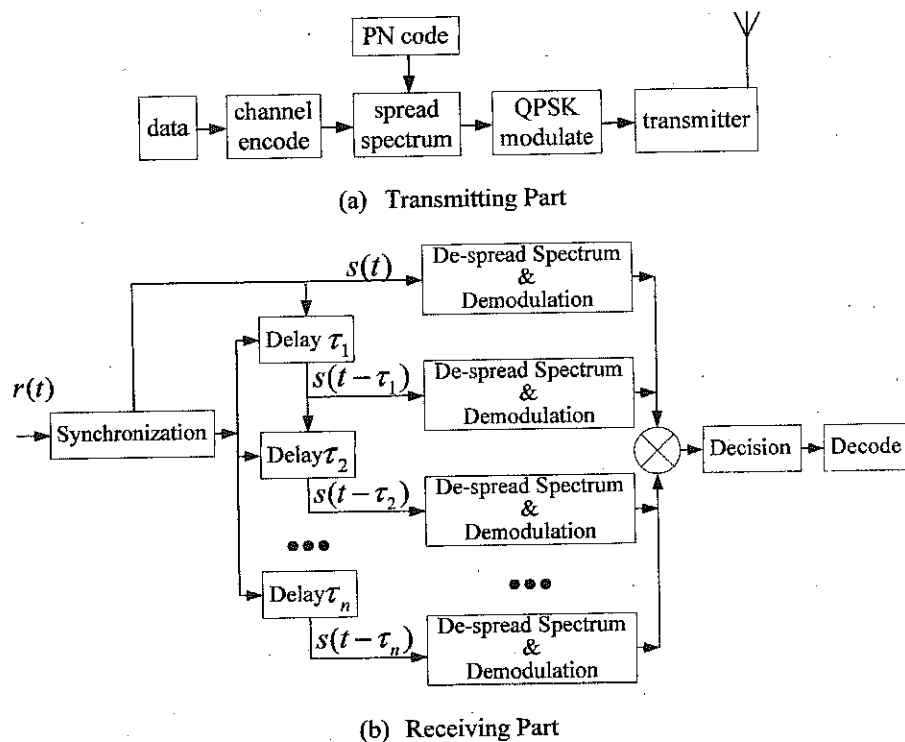

Figure 7. The Principle Model of the Communication System

#### 4. Simulation Results

This part will give the simulation results. The original data and the received data, the frequency spectrogram and the BER curve are included.

##### 4.1 Design of the parameters

In the simulation, the bit rate of original digital sequence is 540b/s. The choice of RS code needs comprehensive consideration, because the more errors it can correct the less efficient it is. In this paper, the parameter is (15, 9), it can correct three errors and the coding efficiency is 9/15. The bit rate after RS coding is 900b/s. Gold code is selected as the PN code. Gold code is a kind of combined codes of m sequence, which is obtained by modular two addition of optimum pairs of two m sequences with the same length, the same rate and the different codes. Its characteristics of

autocorrelation and crosscorrelation are very good and the number of address code is much more than that of m sequence. The order is 5, the length is  $2^5 - 1 = 31$  and the spreading gain is  $10\lg 31 = 14.9$  dB. The bit rate after spread spectrum is 27.9kb/s.

The transmission distance is 1km from the users to the console on condition that the sound velocity is 1520m/s. Also we suppose that there are three transmission paths in the communication channel. One is direct path and the other two are reflection paths. The transmission delay of the two reflection paths are 0.159s and 0.093s respectively. The transmission losses of the three paths are 7.2dB, 8.9dB and 8.2dB respectively.

For the convenient of simulation, we suppose there are two users in the system. In fact, because of the good autocorrelation and crosscorrelation of Gold code, the number of users has little influence on the communication effect.

### 4.2 Graph of the signal

Figure 8 shows the original and the received signal of the communication system. From them we notice that when the SNR is -10dB, the original signal can be recovered correctly in the receiving part and the two users can communicate simultaneously successfully. When the SNR is raised at -20dB, some errors have appeared. In this condition, the system can't work normally.

Figure 9, Figure 10 and Figure 11 show the frequency spectrogram, the scatter plot and the eye diagram of the composite signal (user1 and user2) transmitting in the channel after adding AWGN (SNR=-10). The figure indicates that the original signal is submerged in the noise when it is transmitting in the channel. However, due to the adoption of techniques such as spread spectrum, channel coding and Rake receiver, the energy of the noise is reduced in the receiving part and the original signal is recovered.

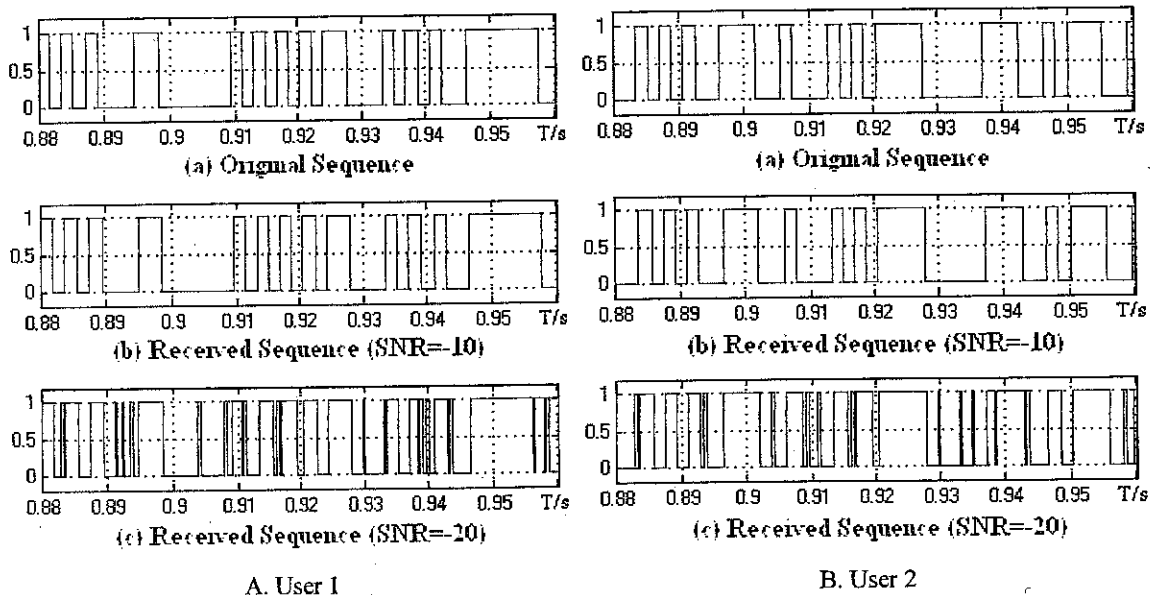

Figure 8. Binary Sequence of Two Users

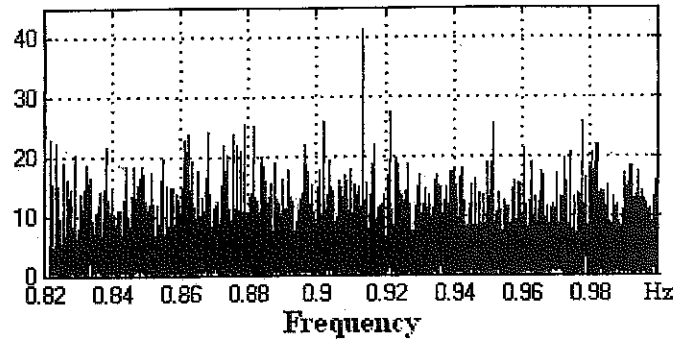

Figure. 9. The Frequency Spectrogram of the Signal

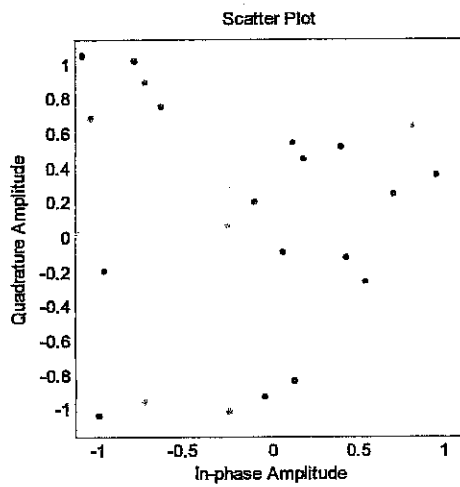

Figure. 10. The Scatter Plot of the Signal

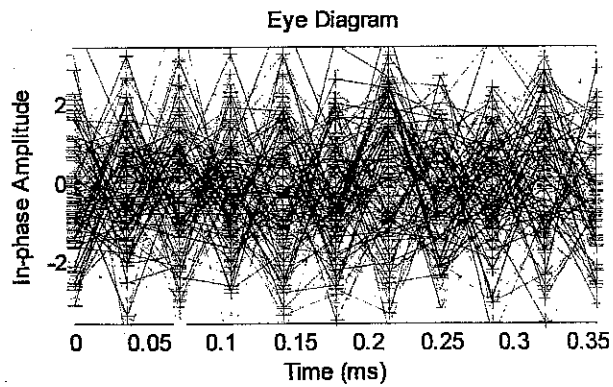

Figure. 11. The Eye Diagram of the Signal

### 4.3 Discussion of BER

BER is a most important index to estimate the performance of a communication system. In fact, because of the existence of the channel and the noise caused by hardware itself, there are always errors in the communication. What we could do is to reduce the errors to a certain degree according to the requirement so that they can't affect the basic communication. Generally speaking, in the

instruction communication system, the requirement of BER is very strict. Correspondingly, in the voice and image communication system, the requirement of BER is lower. From Figure 12 we can see that when the SNR is -10dB, the BER is  $7.82 \times 10^{-4}$  and it is acceptable in practice.

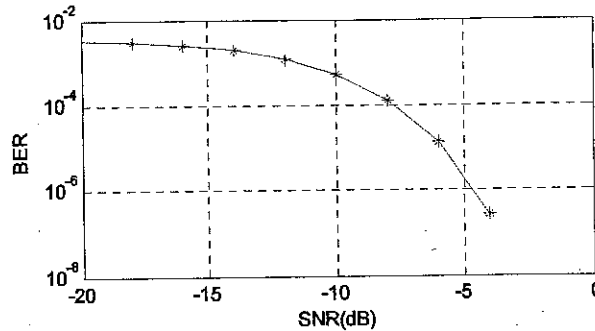

Figure. 12. The Relationship Between BER and SNR

## 5. Conclusions

This paper designs a kind of underwater acoustic communication system based on QPSK-CDMA for multiple underwater vehicles. Some key techniques such as spread spectrum and channel coding are adopted in order to ensure the communication reliability. Besides, Rake Receiver is also an important part in the system to reduce the influence caused by multipath effect, which can greatly reduce the BER. Meanwhile, synchronization parts and underwater acoustic channel are also taken into account. The simulation results indicate that this system could enable multiple vehicles to communicate simultaneously successfully. The system could realize some data and simple voice communication and the BER is  $7.82 \times 10^{-4}$  when the SNR is -10dB, which is acceptable in practice. The theory and the results in this paper have referenced value in the research of underwater acoustic communication.

How to ensure the communication reliability if the original bit rate rises is also a very important problem in underwater acoustic communication system, which is worth doing research further in the future.

## 6. Acknowledgement

This research is supported by Kagawa University Characteristic Prior Research Fund 2009.

## References

- [1] N. Richard, U. Mitra, "Sparse channel estimation for cooperative underwater communications: A structured multichannel approach", Acoustics, Speech and Signal Processing 2008, ICASSP 2008, IEEE International Conference, pp. 5300-5303.
- [2] Sung-Hoon Byun, Sea-Moon Kim, Yong-Kon Lim, etc, "Time-varying Underwater Acoustic Channel Modeling for Moving Platform", Oceans 2007, pp. 1-4.
- [3] Aijun Song, M. Badiy, "Generalized Equalization for Underwater Acoustic Communications", OCEANS 2005, Proceedings of MTS/IEEE 2005, vol. 2, pp. 1522-1527.

- [4] S. Roy, T. Duman, L. Ghazikhanian, etc, "Underwater Acoustic Communication Performance Using Space-Time Coding and Processing" OCEANS '04, MTTTS/IEEE TECHNO-OCEAN '04, vol. 1, pp. 26-33.
- [5] Han Jung-Woo, Ju Hyung-Jun, Kim Ki-Man, etc, "A Study on the Cooperative Diversity Technique with Amplify and Forward for Underwater Wireless Communication", OCEANS 2008, MTS/IEEE Kobe Techno-Ocean, pp. 1-3.
- [6] Kun-Chou Lee, Lan-Ting Wang, Jyun-Gu Ou, "Underwater Acoustic Imaging by Diversity Techniques", Oceans 2007, pp. 1-3.
- [7] Trubuil Joel, Goalic Andre, Beuzelin Nicolas, "A LOW BIT-RATE SPEECH UNDERWATER ACOUSTIC PHONE USING CHANNEL CODING FOR QUALITY IMPROVEMENT", Military Communications Conference, 2007, MILCOM 2007, IEEE, pp. 1-7.
- [8] A. Goalie, J. Trubuil, N. Beuzelin, "Channel Coding for Underwater Acoustic Communication System", OCEANS 2006, pp. 1-4.
- [9] Yang, T.C., Wen-Bin Yang, "Low signal-to-noise-ratio underwater acoustic communications using direct-sequence spread-spectrum signals", OCEANS 2007-Europe, 2007, pp. 1-6.
- [10] Stojanovic, M., Freitag, L., "Multichannel Detection for Wideband Underwater Acoustic CDMA Communications", IEEE Journal of Oceanic Engineering, 2006, Volume: 31, Issue: 3, pp. 685-695.
- [11] Eduardo R. B. Marques, José Pinto, etc, "AUV Control and Communication using Underwater Acoustic Networks", OCEANS 2007, Europe, pp. 1-6.
- [12] R. J. Vaccaro, "The Past, Present, and Future of Underwater Acoustic Processing", IEEE SIGNAL PROCESSING MAGAZINE, JULY 1998, pp. 21-51.
- [13] Robert J. Urick, "Principles of Underwater Sound (3rd Edition)", 1983.
- [14] John G. Proakis, "Digital Communications (4th edition)", McGraw-Hill science, 2000.
- [15] Shuxiang Guo, Zixin Zhao, "A CDMA Acoustic Communication System for Multiple Underwater Robots", Proceedings of the 2008 IEEE, International Conference on Robotics and Biomimetics, Thailand, 2008, pp.1522-1526.